

JEE ADVANCED-2016

PHYSICS

General Instructions:



1. This sealed booklet is your Question Paper. Do not break the seal till you are instructed to do so.
2. The question paper CODE is printed on the left hand top corner of this sheet and the right hand top corner of the back cover of this booklet.
3. Use the Optical Response Sheet (ORS) provided separately for answering the questions.
4. The paper CODE is printed on its left part as well as the right part of the ORS. Ensure that both these codes are identical and same as that on the question paper booklet. If not, contact the invigilator.
5. Blank spaces are provided within this booklet for rough work.
6. Write your name and roll number in the space provided on the back cover of this booklet.
7. After breaking the seal of the booklet at 2:00 pm, verify that the booklet contains 36 pages and that all the 54 questions along with the options are legible. If not, contact the invigilator for replacement of the booklet.
8. You are allowed to take away the Question Paper at the end of the examination.

Optical Response Sheet

9. The ORS (top sheet) will be provided with an attached Candidate's Sheet (bottom sheet). The Candidate's Sheet is a carbon – less copy of the ORS.
10. Darken the appropriate bubbles on the ORS by applying sufficient pressure. This will leave an impression at the corresponding place on the Candidate's Sheet.
11. The ORS will be collected by the invigilator at the end of the examination.
12. You will be allowed to take away the Candidate's Sheet at the end of the examination.
13. Do not tamper with or mutilate the ORS. Do not use the ORS for rough work.

14. Write your name, roll number and code of the examination center, and sign with pen in the space provided for this purpose on the ORS. Do not write any of these details anywhere else on the ORS. Darken the appropriate bubble under each digit of your roll number.

Darken the Bubbles on the ORS

15. Use a Black Ball Point Pen to darken the bubbles on the ORS.
16. Darken the bubble  completely.
17. The correct way of darkening a bubble is as: 
18. The ORS is machine – gradable. Ensure that the bubbles are darkened in the correct way.
19. Darken the bubbles only if you are sure of the answer. There is no way to erase or “un-darken” a darkened bubble.

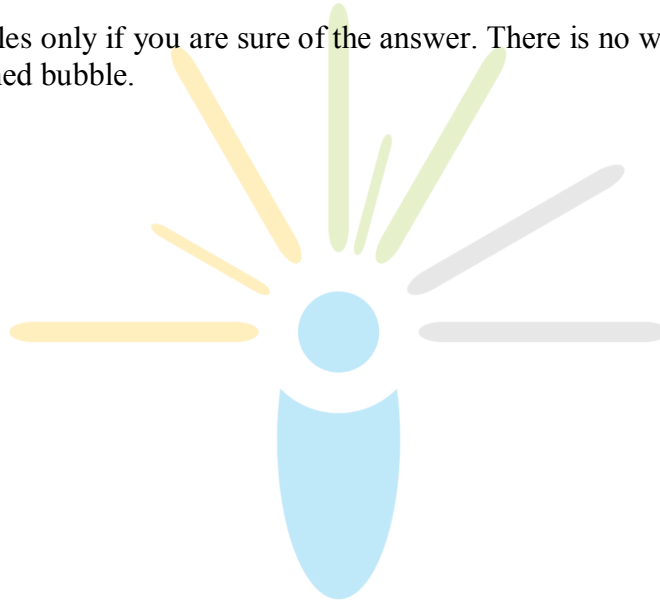

SECTION-1 (Maximum Mark : 18)

- This section contains **SIX** questions.
- Each question has **FOUR** options (A), (B), (C) and (D). **ONLY ONE** of these four options is correct
- For each question, darken the bubble corresponding to the correct option in the **ORS**
- For each question, marks will be awarded in one of the following categories :

Full Marks : +3 If only the bubble corresponding to the correct option is darkened.

Zero Marks : 0 If none of the bubbles is darkened.

Negative Marks : -1 In all other cases.

1. The electrostatic energy of Z protons uniformly distributed throughout a spherical nucleus of radius R is given by $E = \frac{3}{5} \frac{Z(Z-1)e^2}{4\pi\epsilon_0 R}$

The measured masses of the neutron, 1_1H , 1_1N and ${}^{15}_8O$ are $1.008665u$, $1.007825u$, $15.000109u$, u and $15.003065u$ respectively. Given that the radii of both the ${}^{15}_7N$ and ${}^{15}_8O$ nuclei are same, $1u = 931.5 MeV/c^2$ (c is the speed of light) and $\frac{e^2}{(4\pi\epsilon_0)} = 1.44 MeV fm$. Assuming that the difference between the binding energies of ${}^{15}_7N$ and ${}^{15}_8O$ is purely due to the electrostatic energy, the radius of either of the nuclei is ($1fm = 10^{-15}m$)

- (A) $2.85 fm$
- (B) $3.03 fm$
- (C) $3.42 fm$
- (D) $3.80 fm$

2. The ends Q and R of two thin wires, PQ and RS , are soldered (joined) together. Initially each of the wires has a length of $1m$ at $10^{\circ}C$. Now the end P is maintained at $10^{\circ}C$, while the end S is heated and maintained at $400^{\circ}C$. The system is thermally insulated from its surroundings. If the thermal conductivity of wire PQ is twice that of the wire RS and the coefficient of linear thermal expansion of PQ is $1.2 \times 10^{-5} K^{-1}$, the change in length of the wire PQ is
- (A) 0.78 mm
(B) 0.90 mm
(C) 1.56 mm
(D) 2.34 mm
3. An accident in a nuclear laboratory resulted in deposition of a certain amount of radioactive material of half-life 18 days inside the laboratory. Tests revealed that the radiation was 64 times more than the permissible level required for safe operation of the laboratory. What is the minimum number of days after which the laboratory can be considered safe for use?
- (A) 64
(B) 90
(C) 108
(D) 120
4. There are two vernier calipers both of which have 1 cm divided into 10 equal divisions on the main scale. The Vernier scale of one of the calipers (C_1) has 10 equal divisions that correspond to 9 main scale divisions. The Vernier scale of the other caliper (C_2) has 10 equal divisions that correspond to 11 main scale divisions. The readings of the two calipers are shown in the figure. The measured values (in cm) by calipers C_1 and C_2 respectively, are

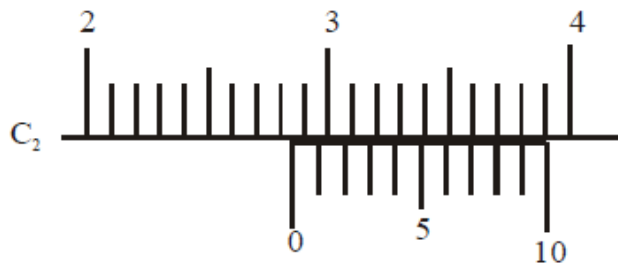
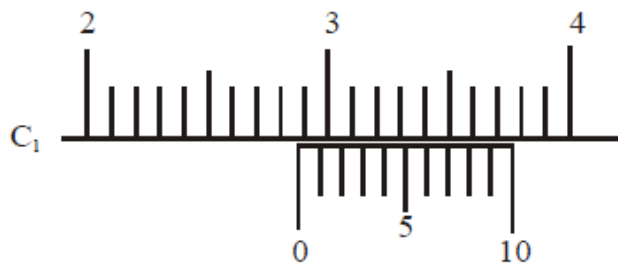

- (A) 2.87 and 2.86
- (B) 2.87 and 2.87
- (C) 2.87 and 2.83
- (D) 2.85 and 2.82

5. A gas is enclosed in a cylinder with a movable frictionless piston. Its initial thermodynamic state at pressure $P_i = 10^5 Pa$ and volume $V_i = 10^{-3} m^3$ changes to a final state at $P_f = \left(\frac{1}{32}\right) \times 10^5 Pa$ and $V_f = 8 \times 10^{-3} m^3$ in an adiabatic quasi-static process, such that $P^3V^5 = \text{constant}$. Consider another thermodynamic process that brings the system from the same initial state to the same final state in two steps: an isobaric expansion at P_i followed by an isochoric (isovolumetric) process at volumes V_f . The amount of heat supplied to the system in the two step process is approximately

- (A) 112 J
- (B) 294 J
- (C) 588 J
- (D) 813 J

6. A small object is placed 50 cm to the left of thin convex lens of focal length 30 cm . A convex spherical mirror of radius of curvature 100 cm is placed to the right of the lens at a distance of 50 cm . The mirror is tilted such that the axis of the mirror is at an angle $\theta = 30^\circ$ to the axis of the lens, as shown in the figure. If the origin of the coordinate system is taken to be at the centre of the lens, the coordinates (in cm) of the point (x, y) at which the image is formed are :

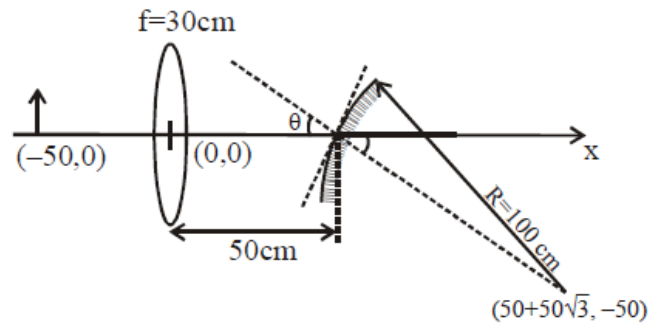

- (A) $(25, 25\sqrt{3})$
 (B) $(\frac{125}{3}, \frac{25}{\sqrt{3}})$
 (C) $(50 - 25\sqrt{3}, 25)$
 (D) $(0,0)$

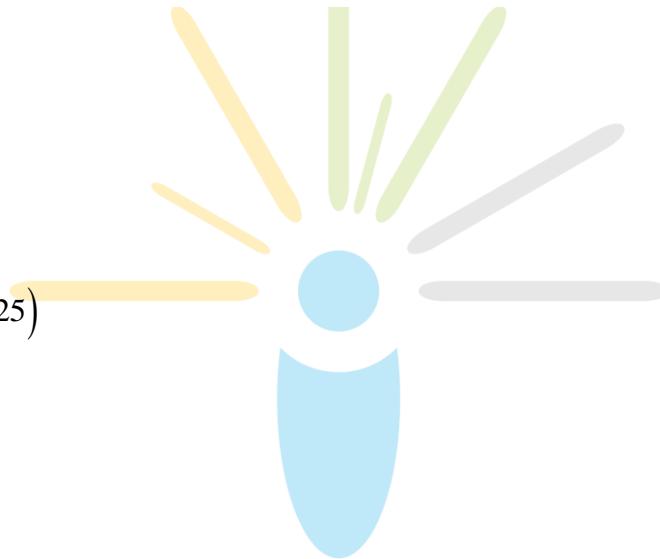

SECTION-2 (Maximum Mark : 32)

- This section contains **EIGHT** questions.
- Each question has **FOUR options** for correct answer(s). **ONE OR MORE THAN ONE** of these four option(s) is (are) correct option(s).
- For each question, darken the bubble(s) corresponding to all the correct option(s) in the ORS
- For each question, marks will be awarded in one of the following categories :

Full Marks : +4 If only the bubble(s) corresponding to the correct option(s) is (are) darkened.

Partial Marks : +1 For darkening a bubble corresponding **to each correct option**, Provided NO incorrect option is darkened.

Zero Marks : 0 If none of the bubbles is darkened.

Negative Marks : -2 In all other cases

- for example, if (A), (C) and (D) are all the correct options for a question, darkening all these three will result in +4 marks; darkening only (A) and (D) will result in +2 marks; and darkening (A) and (B) will result in -2 marks, as a wrong option is also darkened

7. While conducting the Young's double slit experiment, a student replaced the two slits with a large opaque plate in the $x - y$ plane containing two small holes that act as two coherent point sources (S_1, S_2) emitting light of wavelength 600 nm . The student mistakenly placed the screen parallel to the $x - z$ plane (for $z > 0$) at a distance $D = 3 \text{ m}$ from the mid-point of $S_1 S_2$, as shown schematically in the figure. The distance between the sources $d = 0.6003 \text{ mm}$. The origin O is at the intersection of the screen and the line joining $S_1 S_2$. Which of the following is (are) true of the intensity pattern on the screen ?

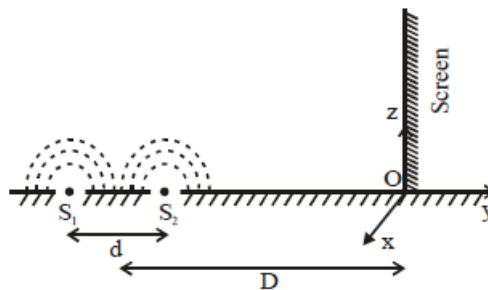

- (A) Hyperbolic bright and dark bands with foci symmetrically placed about O in the x -direction
- (B) Semi circular bright and dark bands centered at point O
- (C) The region very close to the point O will be dark
- (D) Straight bright and dark bands parallel to the x -axis
8. In an experiment to determine the acceleration due to gravity g , the formula used for the time period of a periodic motion is $T = 2\pi\sqrt{\frac{7(R-r)}{5g}}$. The values of R and r are measured to be (60 ± 1) mm and (10 ± 1) mm, respectively. In five successive measurements, the time period is found to be $0.52s, 0.56s, 0.57s, 0.54s$ and $0.59s$. The least count of the watch used for the measurement of time period is $0.01s$. Which of the following statement(s) is(are) true ?
- (A) The error in the measurement of r is 10%
- (B) The error in the measurement of T is 3.57%
- (C) The error in the measurement of T is 2%
- (D) The error in the determined value of g is 11%
9. A rigid wire loop of square shape having side of length L and resistance R is moving along the x -axis with a constant velocity v_0 in the plane of the paper. At $t = 0$, the right edge of the loop enters a region of length $3L$ where there is a uniform magnetic field B_0 into the plane of the paper, as shown in the figure. For sufficiently large v_0 , the loop eventually crosses the region. Let x be the location of the right edge of the loop. Let $v(x)$, $I(x)$ and $F(x)$ represent the velocity of the loop, current in the loop, and force on the loop, respectively, as a function of x . Counter-clockwise current is taken as positive.

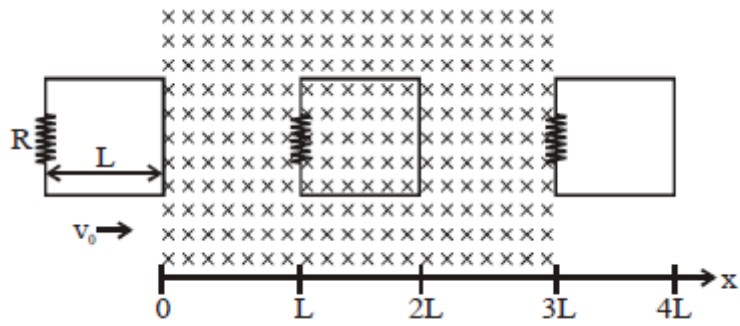

Which of the following schematic plot(s) is(are) correct ? (Ignore gravity)

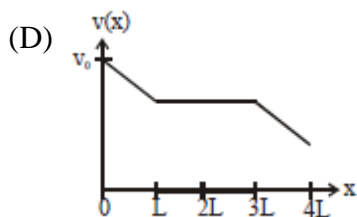
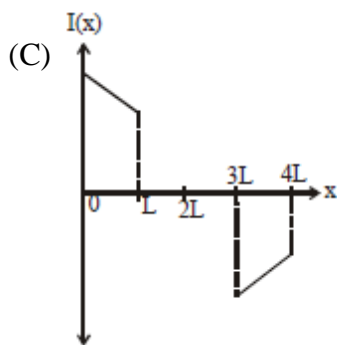
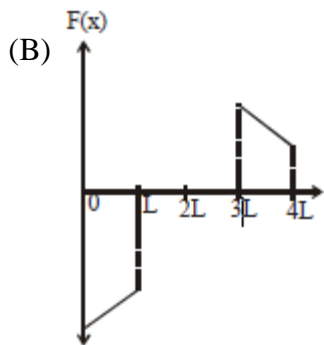
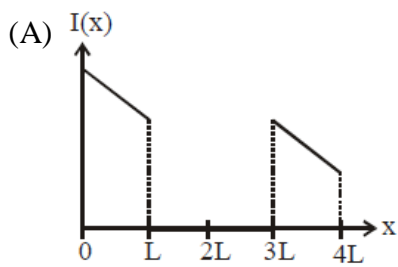

10. Light of wavelength λ_{ph} falls on a cathode plate inside a vacuum tube as shown in the figure. The work function of the cathode surface is ϕ and the anode is a wire mesh of conducting material kept at a distance d from the cathode. A potential difference V is maintained between the electrodes. If the minimum de Broglie wavelength of the electrons passing through the anode is λ_e , which of the following statement(s) is(are) true ?

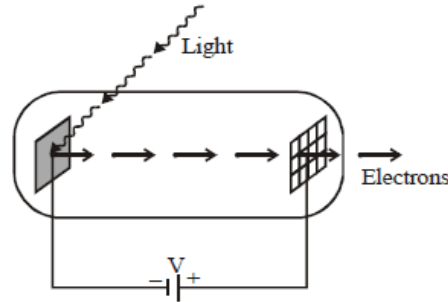

- (A) For large potential difference ($V \gg \phi/e$), λ_e is approximately halved if V is made four times
- (B) λ_e increases at the same rate as λ_{ph} for $\lambda_{ph} < \lambda_{ph} < hc/\phi$
- (C) λ_e is approximately halved, if d is doubled
- (D) λ_e decreases with increase in ϕ and λ_{ph}

11. Two thin circular discs of mass m and $4m$, having radii of a and $2a$, respectively, are rigidly fixed by a massless, right rod of length $\ell = \sqrt{24a}$ through their center. This assembly is laid on a firm and flat surface, and set rolling without slipping on the surface so that the angular speed about the axis of the rod is ω . The angular momentum of the entire assembly about the point 'O' is \vec{L} (see the figure). Which of the following statement(s) is(are) true ?

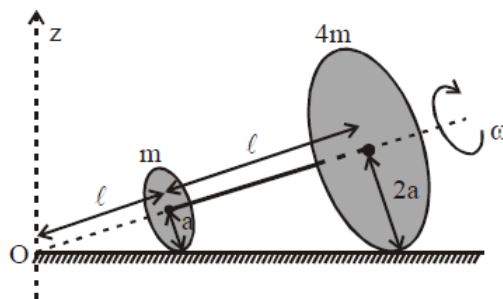

- (A) The magnitude of angular momentum of the assembly about its center of mass is $17ma^2 \omega/2$
- (B) The magnitude of the z -component of \vec{L} is $55ma^2\omega$
- (C) The magnitude of angular momentum of center of mass of the assembly about the point O is $81ma^2\omega$
- (D) The center of mass of the assembly rotates about the z -axis with an angular speed of $\omega/5$
- 12.** Consider two identical galvanometers and two identical resistors with resistance R . If the internal resistance of the galvanometers $R_G < R/2$, which of the following statement(s) about any one of the galvanometers is(are) true ?
- (A) The maximum voltage range is obtained when all the components are connected in series
- (B) The maximum voltage range is obtained when the two resistors and one galvanometer are connected in series, and the second galvanometer is connected in parallel to the first galvanometer
- (C) The maximum current range is obtained when all the components are connected in parallel
- (D) The maximum current range is obtained when the two galvanometers are connected in series and the combination is connected in parallel with both the resistors.

13. In the circuit shown below, the key is pressed at time $t = 0$. Which of the following statement(s) is(are) true?

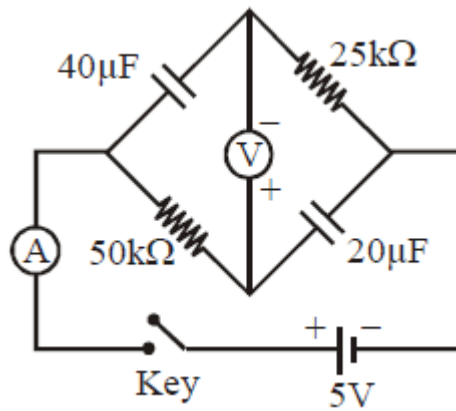

- (A) The voltmeter displays $-5V$ as soon as the key is pressed, and displays $+5V$ after a long time
- (B) The voltmeter will display $0V$ at time $t = \ln 2$ seconds
- (C) The current in the ammeter becomes $1/e$ of the initial value after 1 second
- (D) The current in the ammeter becomes zero after a long time
14. A block with mass M is connected by a massless spring with stiffness constant k to a rigid wall and moves without friction on a horizontal surface. The block oscillates with small amplitude A about an equilibrium position x_0 . Consider two cases : (i) when the block is at x_0 ; and (ii) when the block is at $x = x_0 + A$. In both the cases, a particle with mass $m (< M)$ is softly placed on the block after which they stick to each other. Which of the following statement(s) is(are) true about the motion after the mass m is placed on the mass M ?

- (A) The amplitude of oscillation in the first case changes by a factor of $\sqrt{\frac{M}{m+M}}$, whereas in the second case it remains unchanged
- (B) The final time period of oscillation in both the cases is same
- (C) The total energy decreases in both the cases
- (D) The instantaneous speed at x_0 of the combined masses decreases in both the cases.

SECTION-3 (Maximum Mark : 15)

- This section contains **TWO** questions.
- Based on each paragraph, there are TWO questions.
- Each question has FOUR options (A), (B), (C) and (D) ONLY ONE of these four options is correct.
- For each question, darken the bubble corresponding to the correct integer in the ORS.
- For each question, marks will be awarded in one of the following categories :

Full Marks : +3 If only the bubble corresponding to the correct is darkened.

Zero Marks : 0 In all other cases.

PARAGRAPH 1

A frame of reference that is accelerated with respect to an inertial frame of reference is called a noninertial frame of reference. A coordinate system fixed on a circular disc rotating about a fixed axis with a constant angular velocity ω is an example of a non-inertial frame of reference. The relationship between the force \vec{F}_{rot} experienced by a particle of mass m moving on the rotating disc and the force \vec{F}_{in} experienced by the particle in an inertial frame of reference is

$$\vec{F}_{rot} = \vec{F}_{in} + 2m(\vec{v}_{in} + 2m)(\vec{v}_{rot} \times \vec{\omega}) + m(\vec{\omega} \times \vec{r}) \times \vec{\omega},$$

where \vec{v}_{rot} is the velocity of the particle in the rotating frame of reference and \vec{r} is the position vector of the particle with respect to the centre of the disc.

Now consider a smooth slot along a diameter of a disc of radius R rotating counter-clockwise with a constant angular speed ω about its vertical axis through its center. We assign a coordinate system with the origin at the centre of the disc, the x -axis along the slot, the y -axis perpendicular to the slot and the z -axis along the rotation axis ($\vec{\omega} = \omega \hat{k}$). A small block of mass m is gently placed in the slot at $\vec{r} = (R/2)\hat{i}$ at $t = 0$ and is constrained to move only along the slot.

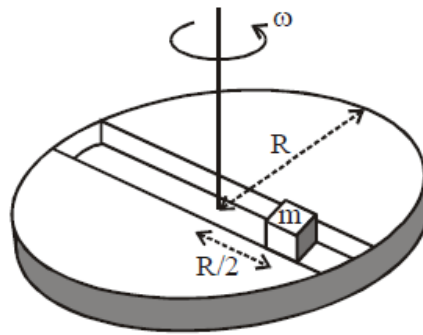

15. The distance r of the block at time t is :

- (A) $\frac{R}{4}(e^{2\omega t} + e^{-2\omega t})$
- (B) $\frac{R}{2} \cos 2\omega t$
- (C) $\frac{R}{2} \cos \omega t$
- (D) $\frac{R}{4}(e^{\omega t} + e^{-\omega t})$

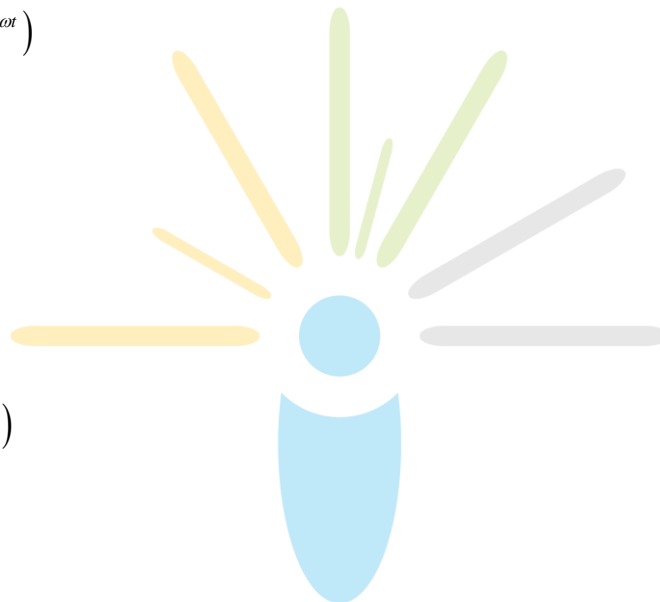

16. The net reaction of the disc on the block is :

- (A) $-m\omega^2 R \cos \omega t \hat{j} - mg \hat{k}$
- (B) $m\omega^2 R \sin \omega t \hat{j} - mg \hat{k}$
- (C) $\frac{1}{2} m\omega^2 R (e^{\omega t} - e^{-\omega t}) \hat{j} + mg \hat{k}$
- (D) $\frac{1}{2} m\omega^2 R (e^{2\omega t} - e^{-2\omega t}) \hat{j} + mg \hat{k}$

PARAGRAPH 2

Consider an evacuated cylindrical chamber of height h having rigid conducting plates at the ends and an insulating curved surface as shown in the figure. A number of spherical balls made of a light weight and soft material and coated with a conducting material are placed on the bottom plate. The balls have a radius $r \ll h$. Now a high voltage source (HV) is connected across the conducting plates such that the bottom plate is at $+V_0$ and the top plate at $-V_0$. Due to their conducting surface, the balls will get charged, will become equipotential with the plate and are repelled by it. The balls will eventually collide with the top plate, where the coefficient of restitution can be taken to be zero due to the soft nature of the material of the balls. The electric field in the chamber can be considered to be that of a parallel plate capacitor. Assume that there are no collision between the balls and the interaction between them is negligible. (Ignore gravity)

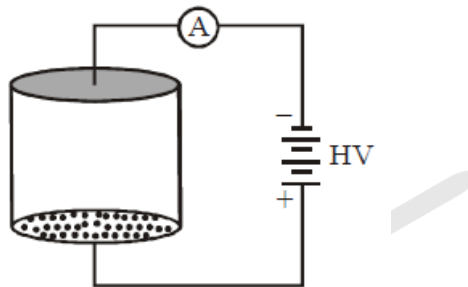

17. Which of the following statements is correct ?

- (A) The balls will bounce back to the bottom plate carrying the opposite charge they went up with
- (B) the balls will execute simple harmonic motion between the two plates
- (C) The balls will bounce back to the bottom plate carrying the same charge they went up with
- (D) The balls will stick to the top plate and remain there

18. The average current in the steady state registered by the ammeter in the circuit will be :

- (A) Proportional to $V_0^{1/2}$
- (B) Proportional to V_0^2
- (C) Proportional to the potential V_0
- (D) Zero

