

JEE MAIN-2008

PHYSICS

A. General Instructions :

Note: (i) The question paper consists of 3 parts (Part II : Physic). Each part has 4 sections.

(ii) **Section I** contains 9 multiple choice questions. Each question has 4 choices (A), (B), (C) and (D), out of which **only one** is correct.

(iii) **Section II** contains 4 questions. Each question contains STATEMENT–1 and STATEMENT–2.

Bubble (A) if both the statements are TRUE and STATEMENT-2 is the correct explanation of STATEMENT-1

Bubble (B) if both the statements are TRUE but STATEMENT-2 is NOT the correct explanation of STATEMENT- 1

Bubble (C) if STATEMENT-1 is TRUE and STATEMENT-2 is FALSE.

Bubble (D) if STATEMENT-1 is FALSE and STATEMENT-2 is TRUE.

(iv) **Section III** contains 3 sets of Linked Comprehension type questions. Each set consists of a paragraph followed by 3 questions. Each question has 4 choices (A), (B), (C) and (D), out of which **only one** is correct.

(v) **Section IV** contains 3 questions. Each question contains statements given in 2 columns. Statements in the first column have to be matched with statements in the second column. The answers to these questions have to be appropriately bubbled in the ORS as per the instructions given at the beginning of the section.

Marking Scheme:

(i) For each question in **Section I**, you will be awarded **3 Marks** if you have darkened only the bubble corresponding to the correct answer and **zero mark** if no bubble is darkened. In all other cases, **minus one (– 1) mark** will be awarded.

(ii) For each question in **Section II**, you will be awarded **3 Marks** if you darken only the bubble corresponding to the correct answer and **zero mark** if no bubble is darkened. In all other cases, **minus one (–1) mark** will be awarded.

(iii) For each question in **Section III**, you will be awarded **4 Marks** if you darken only the bubble corresponding to the correct answer and **zero mark** if no bubble is darkened. In all other cases, **minus one (– 1) mark** will be awarded.

(iv) For each question in **Section IV**, you will be awarded **6 Marks** if you have darkened ALL the bubble corresponding **ONLY** to the correct answer or **awarded 1 mark each** for correct bubbling of answer in any row. **No negative mark will be awarded for an incorrectly bubbled answer.**

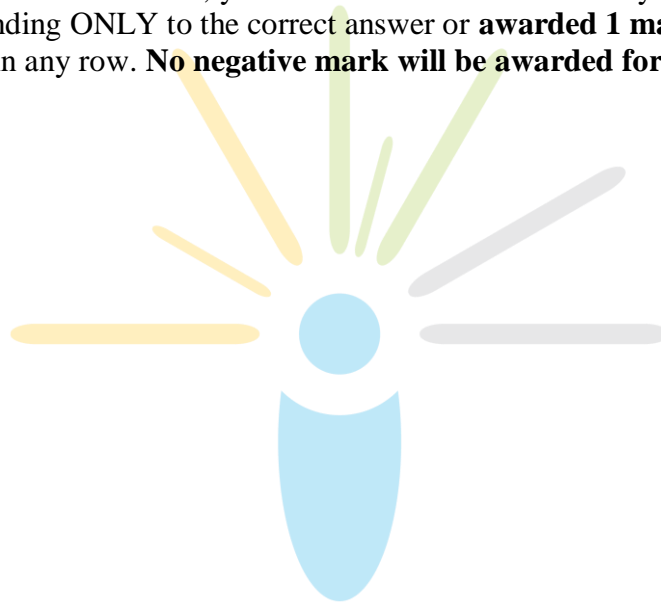

SECTION I

This section contains 9 multiple choice questions. Each question has four choices (A), (B), (C) and (D) out of which ONLY ONE is correct.

23. A glass tube of uniform internal radius (r) has a valve separating the two identical ends. Initially, the valve is in a tightly closed position. End 1 has a hemispherical soap bubble of radius r . End 2 has sub-hemispherical soap bubble as shown in figure. Just after opening the valve,

Figure:

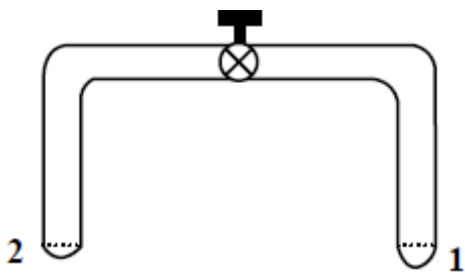

- (A) air from end 1 flows towards end 2. No change in the volume of the soap bubbles
- (B) air from end 1 flows towards end 2. Volume of the soap bubble at end 1 decreases
- (C) no changes occurs
- (D) air from end 2 flows towards end 1. volume of the soap bubble at end 1 increases
24. A block (B) is attached to two unstretched springs S_1 and S_2 with spring constants k and $4k$, respectively (see figure I). The other ends are attached to identical supports M_1 and M_2 , not attached to the walls. The springs and supports have negligible mass. There is no friction anywhere. The block B is displaced towards wall 1 by a small distance x (figure II) and released. The block returns and moves a maximum distance y towards wall 2. Displacements x and y are measured with respect to the equilibrium position of the block B . The ratio $\frac{y}{x}$ is

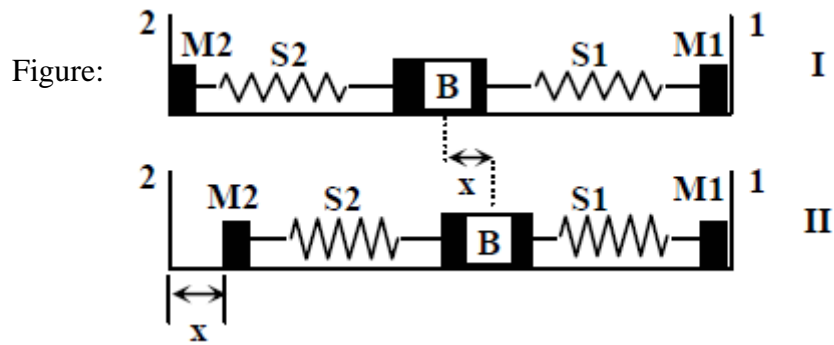

- (A) 4
- (B) 2
- (B) $\frac{1}{2}$
- (D) $\frac{1}{4}$

25. A bob of mass M is suspended by a massless string of length L . The horizontal velocity V at position A is just sufficient to make it reach the point B . The angle θ at which the speed of the bob is half of that at A , satisfies

Figure:

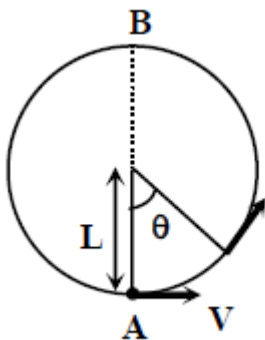

- (A) $\theta = \frac{\pi}{4}$
- (B) $\frac{\pi}{4} < \theta < \frac{\pi}{2}$

(C) $\frac{\pi}{2} < \theta < \frac{3\pi}{4}$

(D) $\frac{3\pi}{4} < \theta < \pi$

26. A parallel plate capacitor C with plates of unit area and separation d is filled with a liquid of dielectric constant $K = 2$. The level of liquid is $\frac{d}{3}$ initially. Suppose the liquid level decreases at a constant speed V , the time constant as a function of time t is

Figure:

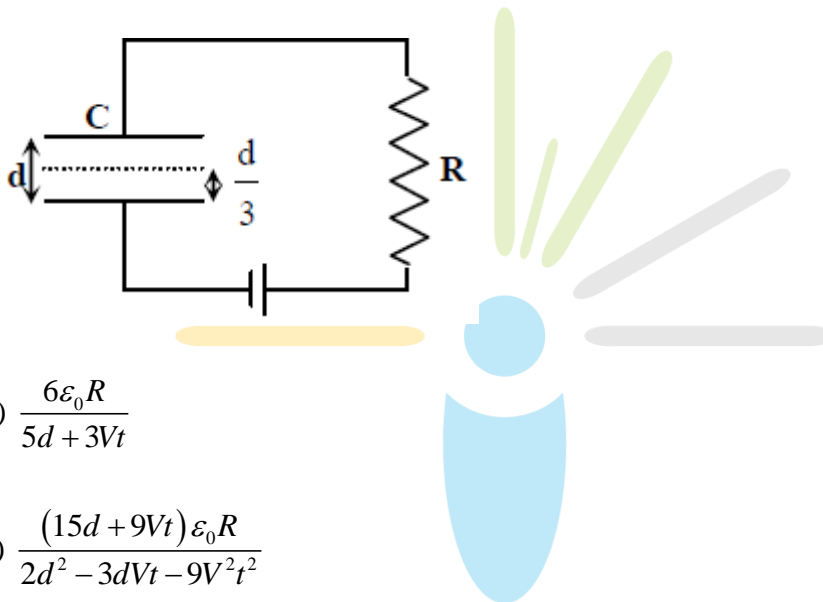

(A) $\frac{6\epsilon_0 R}{5d + 3Vt}$

(B) $\frac{(15d + 9Vt)\epsilon_0 R}{2d^2 - 3dVt - 9V^2 t^2}$

(C) $\frac{6\epsilon_0 R}{5d - 3Vt}$

(D) $\frac{(15d - 9Vt)\epsilon_0 R}{2d^2 - 3dVt - 9V^2 t^2}$

27. A light beam is travelling from Region I to Region IV (Refer Figure). The refractive index in Regions I, II, III and IV are $n_0, \frac{n_0}{2}, \frac{n_0}{6}$ and $\frac{n_0}{8}$, respectively. The angle of incidence θ for which the beam just misses entering Region IV is

Figure:

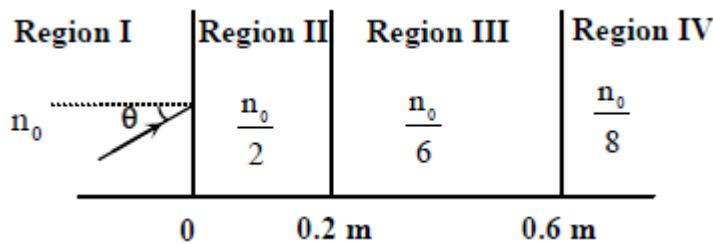

- (A) $\sin^{-1}\left(\frac{3}{4}\right)$
 (B) $\sin^{-1}\left(\frac{1}{8}\right)$
 (C) $\sin^{-1}\left(\frac{1}{4}\right)$
 (D) $\sin^{-1}\left(\frac{1}{3}\right)$



28. A vibrating string of certain length ℓ under a tension T resonates with a mode corresponding to the first overtone (third harmonic) of an air column of length 75 cm inside a tube closed at one end. The string also generates 4 beats per second when excited along with a tuning fork of frequency n . Now when the tension of the string is slightly increased the number of beats reduces 2 per second. Assuming the velocity of sound in air to be 340 m/s , the frequency n of the tuning fork in Hz is

- (A) 344
 (B) 336
 (C) 117.3
 (D) 109.3

29. A radioactive sample S_1 having an activity $5\mu\text{Ci}$ has twice the number of nuclei as another sample S_2 which has an activity of $10\mu\text{Ci}$. The half lives of S_1 and S_2 can be
- (A) 20 years and 5 years, respectively
- (B) 20 years and 10 years, respectively
- (C) 10 years each
- (D) 5 years each
30. A transverse sinusoidal wave moves along a string in the positive x -direction at a speed of 10cm/s . The wavelength of the wave is 0.5 m and its amplitude is 10 cm . At a particular time t , the snap –shot of the wave is shown in figure. The velocity of point P when its displacement is 5 cm is

Figure:

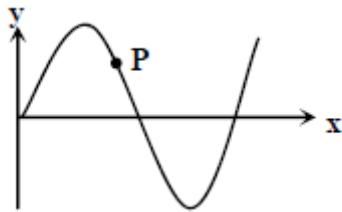

- (A) $\frac{\sqrt{3}\pi}{50} \hat{j} \text{ m/s}$
- (B) $-\frac{\sqrt{3}\pi}{50} \hat{j} \text{ m/s}$
- (C) $\frac{\sqrt{3}\pi}{50} \hat{i} \text{ m/s}$
- (D) $-\frac{\sqrt{3}\pi}{50} \hat{i} \text{ m/s}$

31. Consider a system of three charges $\frac{q}{3}, \frac{q}{3}$ and $-\frac{2q}{3}$ placed at points A, B and C , respectively, as shown in the figure. Take O to be the centre of the circle of radius R and angle $CAB = 60^\circ$

Figure:

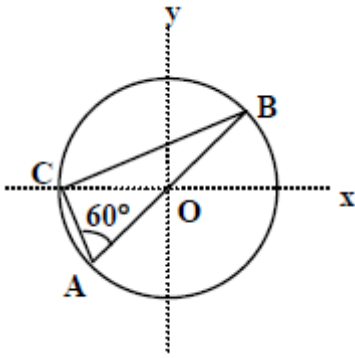

- (A) The electric field at point O is $\frac{q}{8\pi\epsilon_0 R^2}$ directed along the negative x -axis
- (B) The potential energy of the system is zero
- (C) The magnitude of the force between the charges at C and B is $\frac{q^2}{54\pi\epsilon_0 R^2}$
- (D) The potential at point O is $\frac{q}{12\pi\epsilon_0 R}$

SECTION – II

This section contains 4 reasoning type questions. Each question has 4 choices (A), (B), (C) and (D), out of which **ONLY ONE** is correct.

32. STATEMENT-1

For practical purposes, the earth is used as a reference at zero potential in electrical circuits.

and

STATEMENT-2

The electrical potential of a sphere of radius R with charge Q uniformly distributed on the surface is given by $\frac{Q}{4\pi\epsilon_0 R}$.

- (A) STATEMENT-1 is True, STATEMENT-2 is True; STATEMENT-2 is a correct explanation for STATEMENT-1
- (B) STATEMENT-1 is True, STATEMENT-2 is True; STATEMENT-2 is **NOT** a correct explanation for STATEMENT-1
- (C) STATEMENT -1 is True, STATEMENT-2 is False
- (D) STATEMENT -1 is False, STATEMENT-2 is True

33 STATEMENT-1

It is easier to pull a heavy object than to push it on a level ground.

and

STATEMENT-2

The magnitude of frictional force depends on the nature of the two surfaces in contact.

- (A) STATEMENT-1 is True, STATEMENT-2 is True; STATEMENT-2 **is** a correct explanation for STATEMENT-1
- (B) STATEMENT-1 is True, STATEMENT-2 is True; STATEMENT-2 **is NOT** a correct explanation for STATEMENT-1
- (C) STATEMENT -1 is True, STATEMENT-2 is False
- (D) STATEMENT -1 is False, STATEMENT-2 is True

34 STATEMENT-1

For an observer looking out through the window of a fast moving train, the nearby objects appear to move in the opposite direction to the train, while the distant objects appear to be stationary.

and

STATEMENT-2

If the observer and the object are moving at velocities \vec{V}_1 and \vec{V}_2 respectively with reference to a laboratory frame, the velocity of the object with respect to the observer is $\vec{V}_2 - \vec{V}_1$.

- (A) STATEMENT-1 is True, STATEMENT-2 is True; STATEMENT-2 **is** a correct explanation for STATEMENT-1
- (B) STATEMENT-1 is True, STATEMENT-2 is True; STATEMENT-2 **is NOT** a correct explanation for STATEMENT-1
- (C) STATEMENT -1 is True, STATEMENT-2 is False
- (D) STATEMENT -1 is False, STATEMENT-2 is True

35 STATEMENT-1

The sensitivity of a moving coil galvanometer is increased by placing a suitable magnetic material as a core inside the coil.

and

STATEMENT-2

Soft iron has a high magnetic permeability and cannot be easily magnetized or demagnetized.

- (A) STATEMENT-1 is True, STATEMENT-2 is True; STATEMENT-2 is a correct explanation for STATEMENT-1
- (B) STATEMENT-1 is True, STATEMENT-2 is True; STATEMENT-2 is **NOT** a correct explanation for STATEMENT-1
- (C) STATEMENT -1 is True, STATEMENT-2 is False
- (D) STATEMENT -1 is False, STATEMENT-2 is True



SECTION – III

This section contains 2 paragraphs. Based upon each paragraph, 3 multiple choice questions have to be answered. Each question has 4 choices (A), (B), (C) and (D), out of which **ONLY ONE** is correct.

Paragraph for Question Nos. 36 to 38

The nuclear charge (Ze) is non-uniformly distributed within a nucleus of radius R . The charge density $\rho(r)$ [charge per unit volume] is dependent only on the radial distance r from the centre of the nucleus as shown in figure The electric field is only along the radial direction.

Figure:

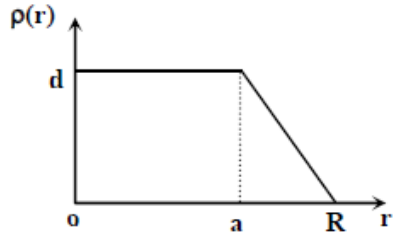

36. The electric field at $r = R$ is

- (A) independent of a
- (B) directly proportional to a
- (C) directly proportional to a^2
- (D) inversely proportional to a

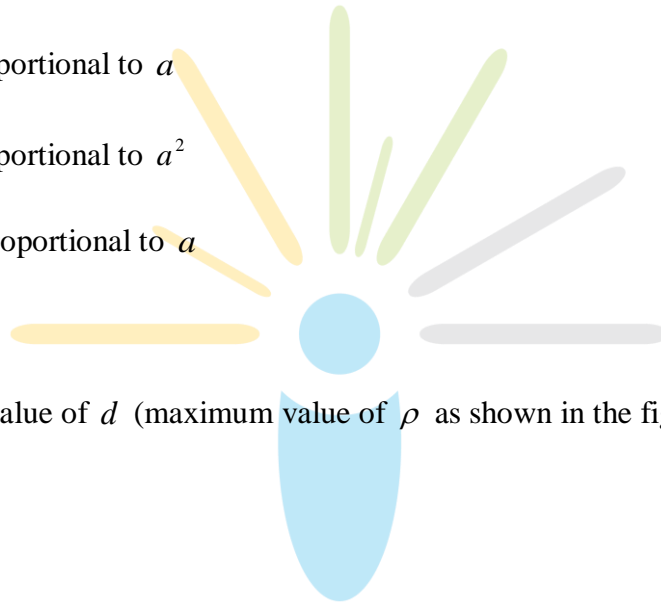

37. For $a = 0$, the value of d (maximum value of ρ as shown in the figure) is

- (A) $\frac{3Ze}{4\pi R^3}$
- (B) $\frac{3Ze}{\pi R^3}$
- (C) $\frac{4Ze}{3\pi R^3}$
- (D) $\frac{Ze}{3\pi R^3}$

38. The electric field within the nucleus is generally observed to be linearly dependent on r . This implies.

(A) $a = 0$

(B) $a = \frac{R}{2}$

(C) $a = R$

(D) $a = \frac{2R}{3}$

Paragraph for Question Nos. 39 to 41

A uniform thin cylindrical disk of mass M and radius R is attached to two identical massless springs of spring constant k which are fixed to the wall as shown in the figure. The springs are attached to the axle of the disk symmetrically on either side at a distance d from its centre. The axle is massless and both the springs and the axle are in horizontal plane. The unstretched length of each spring is L . The disk is initially at its equilibrium position with its centre of mass (CM) at a distance L from the wall. The disk rolls without slipping with velocity $\vec{V}_0 = V_0 \hat{i}$. The coefficient of friction is μ .

Figure:

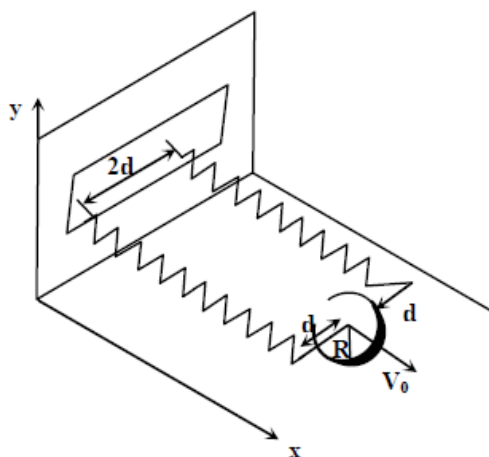

39. The net external force acting on the disk when its centre of mass is at displacement x with respect to its equilibrium position is

(A) $-kx$

(B) $-2kx$

(C) $-\frac{2kx}{3}$

(D) $-\frac{4kx}{3}$

40. The centre of mass of the disk undergoes simple harmonic motion with angular frequency ω equal to

(A) $\sqrt{\frac{k}{M}}$

(B) $\sqrt{\frac{2k}{M}}$

(C) $\sqrt{\frac{2k}{3M}}$

(D) $\sqrt{\frac{4k}{3M}}$

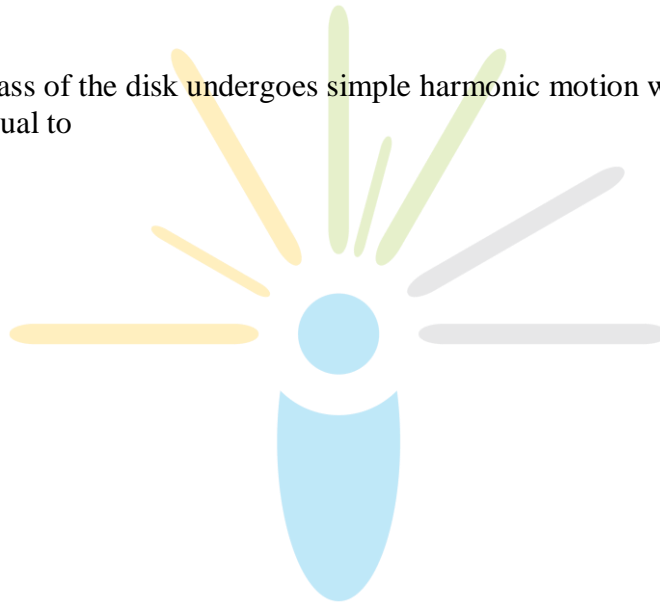

41. The maximum value of V_0 for which the disk will roll without slipping is

(A) $ug\sqrt{\frac{M}{k}}$

(B) $ug\sqrt{\frac{M}{2k}}$

(C) $ug\sqrt{\frac{3M}{k}}$

(D) $ug\sqrt{\frac{5M}{2k}}$

