

## IIT-JEE-2004

### Physics

[Time allowed: 2 hours]

**Note:** Question number 1 to 10 carries **2 marks** each and 11 to 20 carries **4 marks** each.

1. A long wire of negligible thickness and mass per unit length  $\lambda$  is floating in a liquid such that the top surface of liquid dips by a distance '  $y$  '. If the length of base of vessel is  $2a$ , find surface tension of the liquid. ( $y \ll a$ )

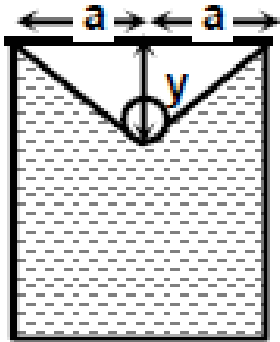

2. An ideal diatomic gas is enclosed in an insulated chamber at temperature 300K . The chamber is closed by a freely movable massless piston, whose initial height from the base is 1m . Now the gas is heated such that its temperature becomes 400K at constant pressure. Find the new height of the piston from the base.

If the gas is compressed to initial position such that no exchange of heat takes place, find the final temperature of the gas.

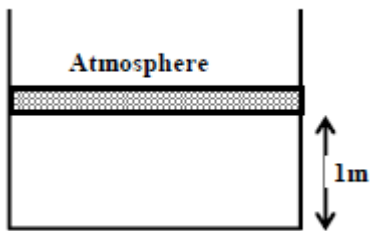

3. In Searle's apparatus diameter of the wire was measured 0.05 cm by screw gauge of least count 0.001 cm . The length of wire was measured 110 cm by meter scale of least count 0.1 cm . An external load of 50 N was applied. The extension in length of wire was measured 0.125 cm by micrometer of least count 0.001 cm . Find the maximum possible error in measurement of young's modulus.

4. Two infinitely large sheets having charge densities  $\sigma_1$  and  $\sigma_2$  respectively ( $\sigma_1 > \sigma_2$ ) are placed near each other separated by distance '  $d$  '. A charge '  $Q$  ' is placed in between two plates such that there is no effect on charge distribution on plates. Now this charge is moved at an angle of  $45^\circ$  with the horizontal towards plate having charge density  $\sigma_2$  by distance '  $a$  ' ( $a < d$  ). Find the work done by electric field in the process.

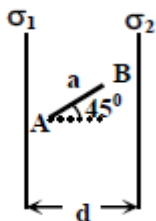

5. An  $\alpha$  -particle and a proton are accelerated from rest through same potential difference and both enter into a uniform perpendicular magnetic field. Find the ratio of their radii of curvature.

6. A small ball of radius ' $r$ ' is falling in a viscous liquid under gravity. Find the dependency of rate of heat produced in terms of radius ' $r$ ' after the drop attains terminal velocity.
7. A syringe of diameter  $D = 8\text{ mm}$  and having a nozzle of diameter  $d = 2\text{ mm}$  is placed horizontally at a height of  $1.25\text{ m}$  as shown in the figure. An incompressible and non-viscous liquid is filled in syringe and the piston is moved at speed of  $0.25\text{ m/s}$ . Find the range of liquid jet on the ground.

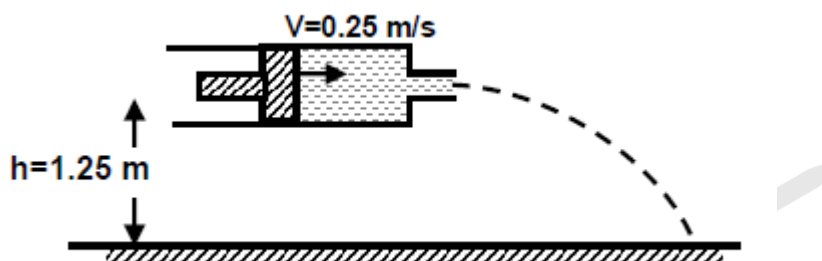

8. A light ray is incident on an irregular shaped slab of refractive index  $\sqrt{2}$  at an angle of  $45^\circ$  with the normal on the incline face as shown in the figure. The ray finally emerges from the curved surface in the medium of the refractive index  $\mu = 1.514$  and passes through point  $E$ . If the radius of curved surface is equal to  $0.4\text{ m}$ , find the distance  $OE$  correct upto two decimal places.

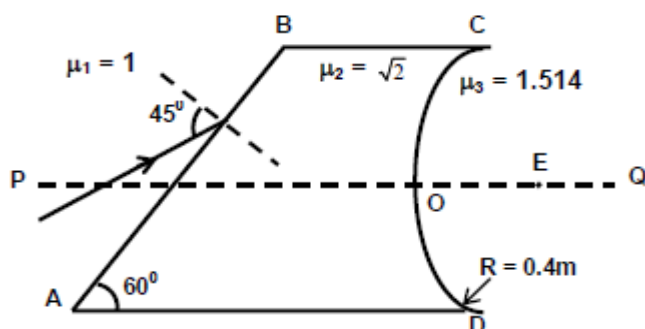

9. A screw gauge of pitch 1mm has a circular scale divided into 100 divisions. The diameter of a wire is to be measured by above said screw gauge. The main scale reading is 1mm and 47<sup>th</sup> circular division coincides with main scale. Find the curved surface area of wire in true significant figures. (Given the length of wire is equal to 5.6 cm and there is no zero-error in the screw gauge.)

10. The age of a rock containing lead and uranium is equal to  $1.5 \times 10^9$  yrs. The uranium is decaying into lead with half life equal to  $4.5 \times 10^9$  yrs. Find the ratio of lead to uranium present in the rock, assuming initially no lead was present in the rock. (Given  $2^{1/3} = 1.259$ )

11. An inductor of inductance ( $L$ ) equal to 35 mH and resistance ( $R$ ) equal to  $11\Omega$  are connected in series to an AC source. The rms voltage of a.c. source is 220 volts and frequency is 50Hz.

(a) Find the peak value of current in the circuit.

(b) Plot the current ( $I$ ) vs ( $\omega t$ ) curve on the given voltage vs ( $\omega t$ ) curve. (Given  $\pi = \frac{22}{7}$ )

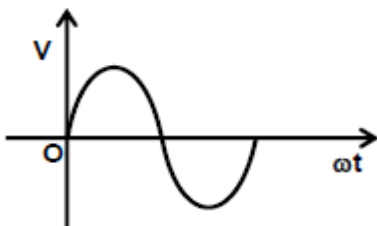

12. Two identical blocks  $A$  and  $B$  are placed on a rough inclined plane of inclination  $45^\circ$ . The coefficient of friction between block  $A$  and incline is 0.2 and that of between  $B$  and incline is 0.3. The initial separation between the two blocks is  $\sqrt{2}$  m. The two blocks are released from rest, then find

- (a) the time after which front faces of both blocks come in same line and
- (b) the distance moved by each block for attaining above position.

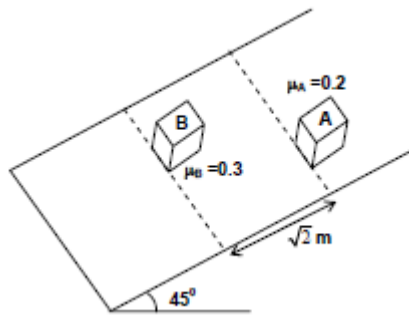

13. In a photoelectric setup, the radiations from the Balmer series of hydrogen atom are incident on a metal surface of work function  $2eV$ . The wavelength of incident radiations lies between  $450\text{nm}$  to  $700\text{nm}$ . Find the maximum kinetic energy of photoelectron emitted. (Given  $hc/e = 1242\text{eV} - \text{nm}$ ).

14. A spherical ball of radius  $R$ , is floating in a liquid with half of its volume submerged in the liquid. Now the ball is displaced vertically by small distance inside the liquid. Find the frequency of oscillation of ball.

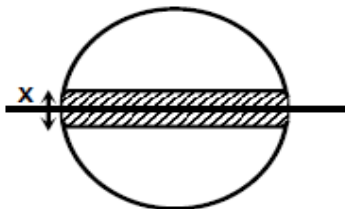

15. The two batteries  $A$  and  $B$ , connected in given circuit, have equal e.m.f.  $E$  and internal resistance  $r_1$  and  $r_2$  respectively ( $r_1 > r_2$ ). The switch  $S$  is closed at  $t = 0$ . After long time it was found that terminal potential difference across the battery  $A$  is zero. Find the value

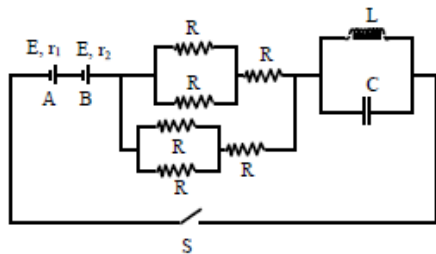

of  $R$

16. A point object is moving with velocity  $0.01\text{m/s}$  on principal axis towards a convex lens of focal length  $0.3\text{m}$ . When object is at a distance of  $0.4\text{m}$  from the lens, find

- (a) rate of change of position of the image, and  
 (b) rate of change of lateral magnification of image.

17. An experiment is performed to verify Ohm's law using a resistor of resistance  $R = 100\Omega$ , a battery of variable potential difference, two galvanometers and two resistances of  $10^6\Omega$  and  $10^{-3}\Omega$  are given. Draw the circuit diagram and indicate clearly position of ammeter and voltmeter.

18. A uniform rod of length  $L$ , conductivity  $K$  is connected from one end to a furnace at temperature  $T_1$ . The other end of rod is at temperature  $T_2$  and is exposed to atmosphere. The temperature of atmosphere is  $T_s$ . The lateral part of rod is insulated. If  $T_2 - T_s \ll T_s, T_2 = T_s + \Delta T$  &  $\Delta T \propto (T_1 - T_s)$ , find proportionality constant of given equation. The heat loss to atmosphere is through radiation only and the emissivity of the rod is  $\epsilon$ .

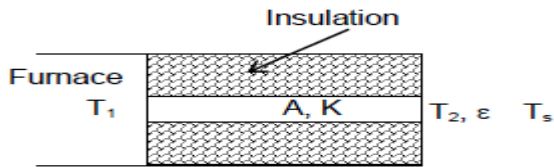

19. A cubical block is floating inside a bath. The temperature of system is increased by small temperature  $\Delta T$ . It was found that the depth of submerged portion of cube does not change. Find the relation between coefficient of linear expansion ( $\alpha$ ) of the cube and volume expansion of liquid ( $\gamma$ ).

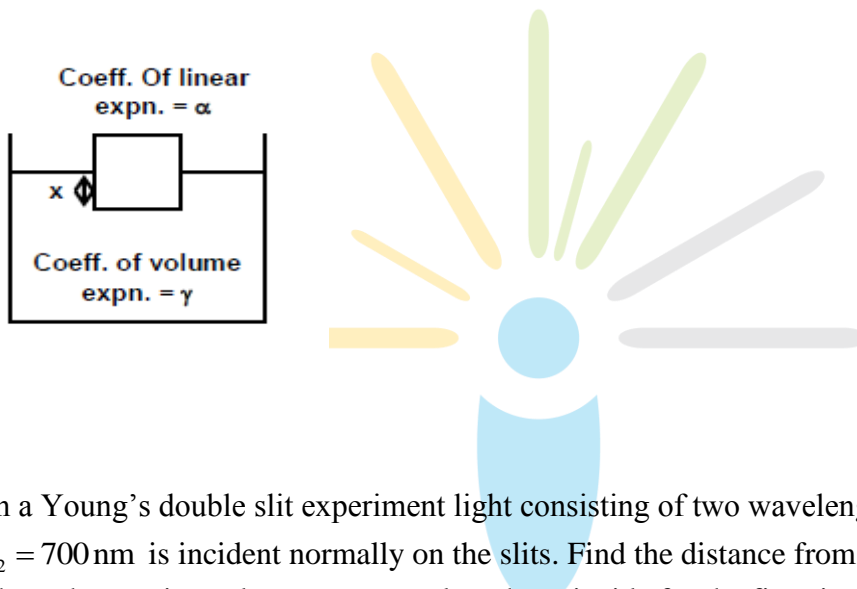

20. In a Young's double slit experiment light consisting of two wavelengths  $\lambda_1 = 500 \text{ nm}$  and  $\lambda_2 = 700 \text{ nm}$  is incident normally on the slits. Find the distance from the central maxima where the maxima due to two wavelengths coincide for the first time after central maxima. (Given  $\frac{D}{d} = 1000$ ) where  $D$  is the distance between the slits and the screen and  $d$  is the separation between the slits.