

JEE MAIN-2012

PHYSICS

[Time: 3 hours] [Maximum Marks: 198]

GENERAL INSTRUCTIONS

A. General:

1. This booklet is your Question paper. Do not break the seals of this booklet before being instructed to do so by the invigilators.
2. The question paper CODE is printed on the right hand top corner of this page and on the back page of this booklet.
3. Blank spaces and blank pages are provided in this booklet for your rough work. No additional sheets will be provided for rough work.
4. Blank papers, clipboards, log tables, slide rules, calculators, cameras, cellular phones, pagers, and electronic gadgets are NOT allowed inside the examination hall.
5. Answers to the questions and personal details are to be filled on a two part carbon less paper, which is provided separately. You should not separate these parts. The invigilator will separate them at the end of examination. The upper sheet is machine-gradable Objective Response Sheet (ORS) which will be taken back by the invigilator. You will be allowed to take away the bottom sheet at the end of the examination.
6. **Using a black ball point pen, darken the bubbles on the upper original sheet.** Apply sufficient pressure so that the impression is created on the bottom sheet.
7. DO NOT TAMPER WITH /MUTILATE THE ORS OR THE BOOKLET.
8. On breaking the seals of the booklet check that it contains 36 pages and all 60 questions and corresponding answer choices are legible. Read carefully the instructions printed at the beginning of each section.

B. Filling the Right Part of the ORS:

9. The ORS also has a CODES printed on its left and right parts.
10. Check that the same CODE is printed on the ORS and on this booklet. **IF IT IS NOT THEN ASK FOR A CHANGE OF THE BOOKLET.** Sign at the place provided on the ORS affirming that you have verified that all the code are same.
11. Write your Name, Registration Number and the name of examination centre and sign with pen in the boxes provided on the right part of the ORS. **Do not write any of this information anywhere else.** Darken the appropriate bubble UNDER each digit of your Registration Number in such a way that the impression is created on the bottom sheet. Also darken the paper CODE given on the right side of **ORS(R4)**.

C. Question paper format:

The question paper consists of 3 Section. Each part consists of three sections.

12. **Section I** contains **8 multiple choice questions**. Each question has four choices (A), (B), (C) and (D) out of which **ONLY ONE is correct**.
13. **Section II** contains **3 paragraphs** each describing theory, experiment, data etc. There are **6 multiple choice questions** relating to three paragraphs with **2 questions on each paragraph**. Each question of a particular paragraph has four choices (A),(B). (C) and (D) out of which **ONLY ONE** is correct.
14. Section III contains 6 multiple choice questions. Each question has four choices (A), (B), (C) and (D) out of which **ONE or MORE** are correct.

D. Marking Scheme

15. For each question in Section I and Section II, you will be awarded 3 marks if you darken the bubble corresponding to the correct answer **ONLY** and zero (0) marks if no bubbles are darkened. In all other cases, minus one (-1) mark will be awarded in these sections.
16. For each question in **Section III**, you will be awarded **4 marks** if you darken **ALL** the bubble(s) corresponding to the correct answer(s) **ONLY**. In all other cases **zero (0) marks** will be awarded. **No negative marks** will be awarded for incorrect answer(s) in this section.

SECTION I

This section contains **8 multiple choice questions**. Each question has four choices (A), (B), (C) and (D) out of **which ONLY ONE is correct**.

1. Two identical discs of same radius R are rotating about their axes in opposite directions with the same constant angular speed ω . The discs are in the same horizontal plane. At time $t=0$, the points P and Q are facing each other as shown in the figure. The relative speed between the two points P and Q is v_r . In one time period (T) of rotation of the discs, v_r , as a function of time is best represented by

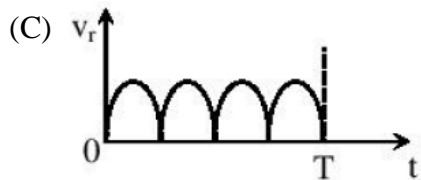
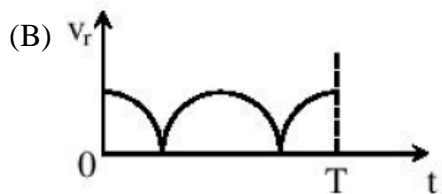
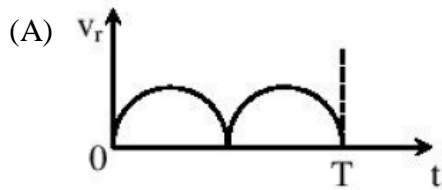
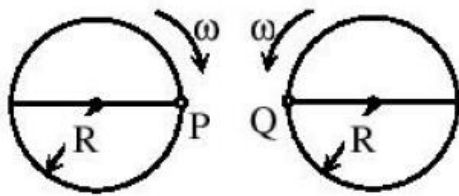

2. A loop carrying current I lies in the $x-y$ plane as shown in the figure. The unit vector k is coming out of the plane of the paper. The magnetic moment of the current loop is

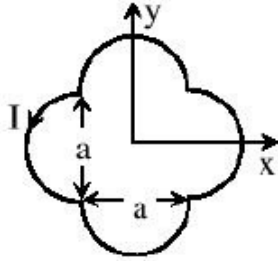

- (A) $a^2 I k$
- (B) $\left(\frac{\pi}{2} + 1\right) a^2 I k$
- (C) $-\left(\frac{\pi}{2} + 1\right) a^2 I k$
- (D) $(2\pi + 1) a^2 I k$

3. An infinitely long hollow conducting cylinder with inner radius $R/2$ and outer radius R carries a uniform current density along its length. The magnitude of the magnetic field, $|\vec{B}|$ as a function of the radial distance r from the axis is best represented by

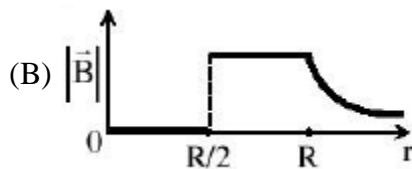
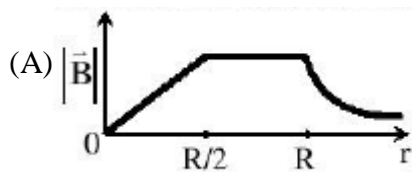

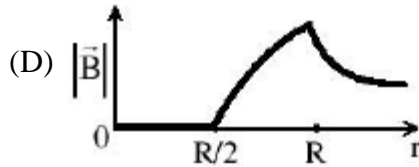
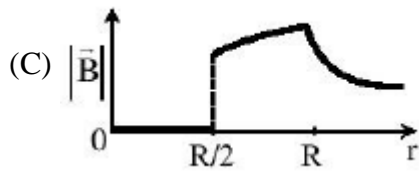

4. A thin uniform cylindrical shell, closed at both ends, is partially filled with water. It is floating vertically in water in half-submerged state. If ρ_c is the relative density of the material of the shell with respect to water, then the correct statement is that the shell is

- (A) more than half-filled if ρ_c is less than 0.5.
 (B) more than half-filled if ρ_c is more than 1.0.
 (C) half-filled if ρ_c is more than 0.5.
 (D) less than half-filled if ρ_c is less than 0.5.

5. In the given circuit, a charge of $+80\mu C$ is given to the upper plate of the $4\mu F$ capacitor. Then in the steady state, the charge on the upper plate of the $3\mu F$ capacitor is

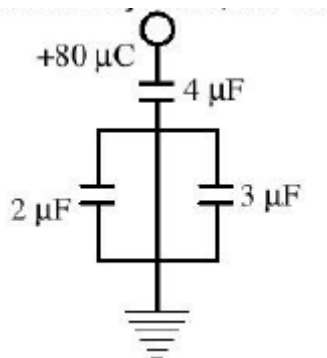

- (A) $+32\mu C$
- (B) $+40\mu C$
- (C) $+48\mu C$
- (D) $+80\mu C$

6. Two moles of ideal helium gas are in a rubber balloon at $30^\circ C$. The balloon is fully expandable and can be assumed to require no energy in its expansion. The temperature of the gas in the balloon is slowly changed to $35^\circ C$. The amount of heat required in raising the temperature is nearly (take $R = 8.31 J/mol.K$)

- (A) 62J
- (B) 104J
- (C) 124J
- (D) 208J

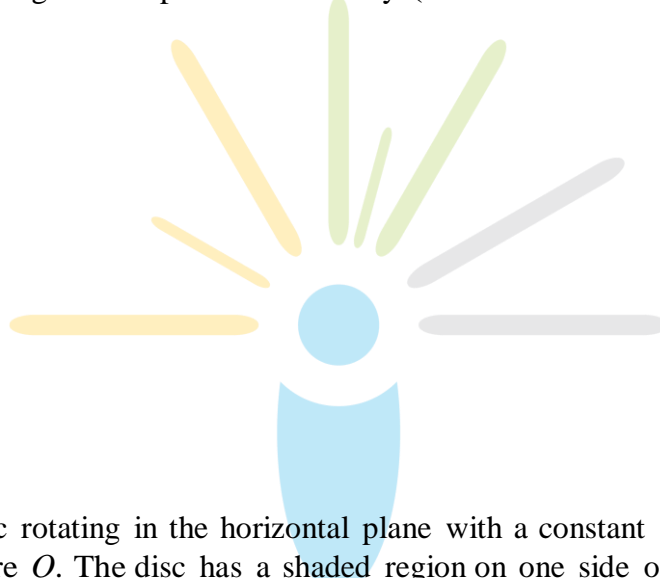

7. Consider a disc rotating in the horizontal plane with a constant angular speed ω about its centre O . The disc has a shaded region on one side of the diameter and an unshaded region on the other side as shown in the figure. When the disc is in the orientation as shown, two pebbles P and Q are simultaneously projected at an angle towards R . The velocity of projection is in the $y-z$ plane and is same for both pebbles with respect to the disc. Assume that (i) they land back on disc before the disc has completed $\frac{1}{8}$ rotation, (ii) their range is less than half the disc radius, and (iii) ω remains constant throughout. Then

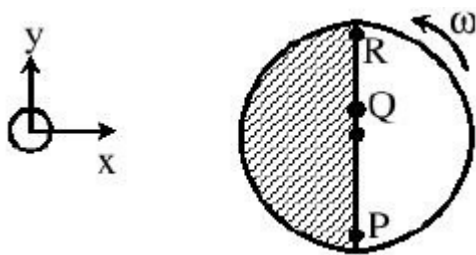

- (A) P lands in the shaded region and Q in the unshaded region.
- (B) P lands in the unshaded region and Q in the shaded region.
- (C) Both P and Q land in the unshaded region.
- (D) Both P and Q land in the shaded region.
8. A student is performing the experiment of resonance Column. The diameter of the column tube is 4cm. The frequency of the tuning fork is 512Hz. The air temperature is 38°C in which the speed of sound is 336m/s. The zero of the meter scale coincides with the top end of the Resonance Column tube. When the first resonance occurs, the reading of the water level in the column is
- (A) 14.0cm
- (B) 15.2cm
- (C) 16.4cm
- (D) 17.6cm

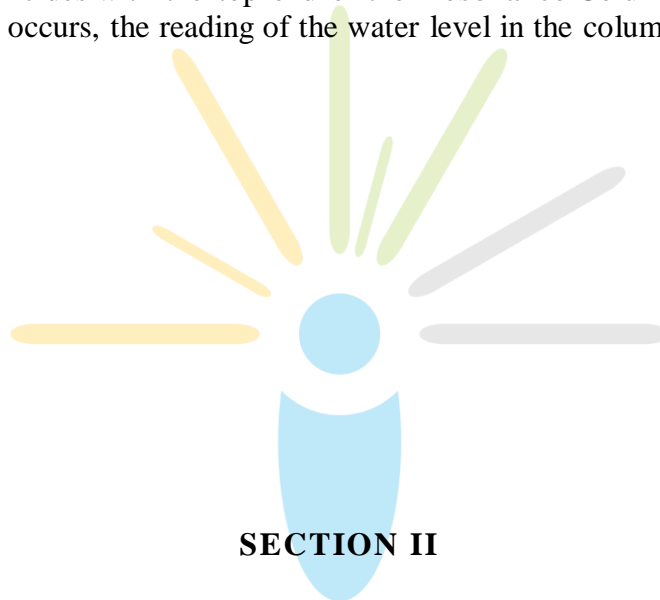

SECTION II

This section contains **6 multiple choice questions** relating to three paragraphs with two questions on each paragraph. Each question has four choices (A), (B), (C) and (D) out of which **ONLY ONE is correct**.

Paragraph for Questions 9 and 10

The general motion of a rigid body can be considered to be a combination of (i) a motion of its centre of mass about an axis, and (ii) its motion about an instantaneous axis passing through the centre of mass. These axes need not be stationary. Consider, for example, a thin uniform disc welded (rigidly fixed) horizontally at its rim to a massless stick, as shown in the figure. When the disc-stick system is rotated about the origin on a horizontal frictionless plane with angular speed ω , the motion at any instant can be taken as a combination of (i) a rotation of the centre of mass of the disc about the z-axis, and (ii) a rotation of the disc through an instantaneous vertical axis passing through its centre of mass (as is seen from the changed orientation of points P and Q). Both these motions have the same angular speed ω in this case

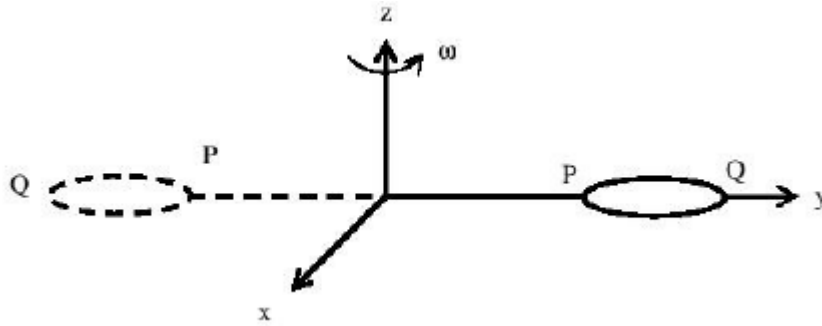

Nov/ consider two similar systems as shown in the figure: Case(a) the disc with its face vertical and parallel to $x-z$ plane; Case (b) the disc with its face making an angle of 45° with $x-y$ plane and its horizontal diameter parallel to x -axis. In both the cases, the disc is welded at point P, and the systems are rotated with constant angular speed to about the z -axis.

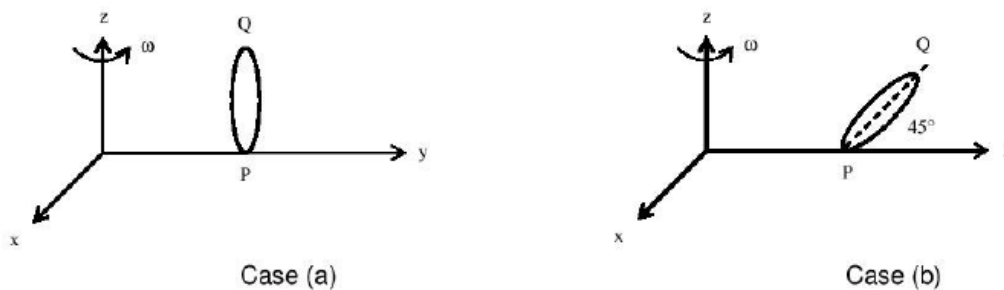

9. Which of the following statements about the instantaneous axis (passing through the centre of mass) is correct?

- (A) It is vertical for both the cases (a) and (b)
- (B) It is vertical for case (a); and is at 45° to the $x-z$ plane and lies in the plane of the disc for case(b).
- (C) It is horizontal for case (a); and is at 45° to the $x-z$ plane and is normal to the plane of the disc for case (b).
- (D) It is vertical for case (a); and is 45° to the $x-z$ plane and is normal to the plane of the disc for case (b).

10. Which of the following statements regarding the angular speed about the instantaneous axis (passing through the centre of mass) is correct?
- (A) It is $\sqrt{2}\omega$ for both the cases.
- (B) It is ω for case (a); and $\frac{\omega}{\sqrt{2}}$ for case (b).
- (C) It is ω for case (a); and $\sqrt{2}\omega$ for case (b).
- (D) It is ω for both the cases.
11. If the anti-neutrino had a mass of $3eV/c^2$ (where c is the speed of light) instead of zero mass, what should be the range of the kinetic energy, K , of the electron?
- (A) $0 \leq K \leq 0.8 \leq 10^6 eV$
- (B) $3.0eV \leq K \leq 0.8 \leq 10^6 eV$
- (C) $3.0eV \leq K < 0.8 \leq 10^6 eV$
- (D) $0 \leq K < 0.8 \leq 10^6 eV$
12. What is the maximum energy of the anti-neutrino?
- (A) Zero
- (B) Much less than $0.8 \times 10^6 eV$.
- (C) Nearly $0.8 \times 10^6 eV$
- (D) Much larger than $0.8 \times 10^6 eV$

Paragraph for Questions 13 and 14

Most materials have the refractive index, $n > 1$. So, when a light ray from air enters a naturally occurring material, then by Snell's law, $\frac{\sin \theta_1}{\sin \theta_2} = \frac{n_2}{n_1}$, it is understood that the refracted ray bends towards the normal. $\sin \theta_2 < \sin \theta_1$, But it never emerges on the same side of the normal as the incident ray. According to electromagnetism, the refractive index of the medium is given by the relation, $n = \left(\frac{c}{v}\right) = \pm\sqrt{\epsilon_r \mu_r}$, where c is the speed of electromagnetic waves in vacuum, v its speed in the medium, ϵ_r and μ_r are the relative permittivity and permeability of the medium respectively.

In normal materials, both ϵ_r and μ_r , are positive, implying positive n for the medium. When both ϵ_r and μ_r , are negative, one must choose the negative root of n . Such negative refractive index materials can now be artificially prepared and are called meta-materials. They exhibit significantly different optical behavior, without violating any physical laws. Since n is negative, it results in a change in the direction of propagation of the refracted light. However, similar to normal materials, the frequency of light remains unchanged upon refraction even in meta-materials.

13. For light incident from air on a meta-material, the appropriate ray diagram is

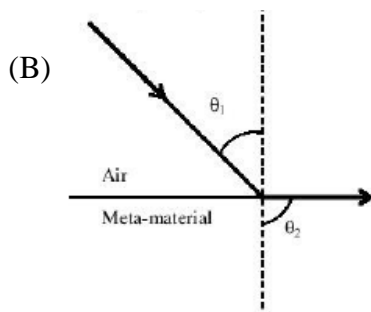
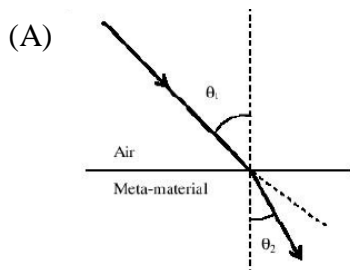

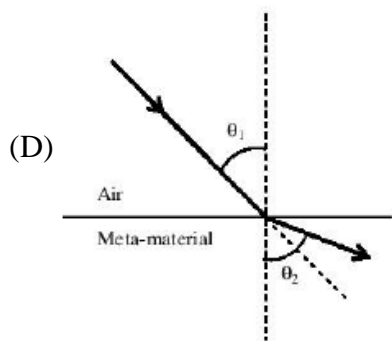
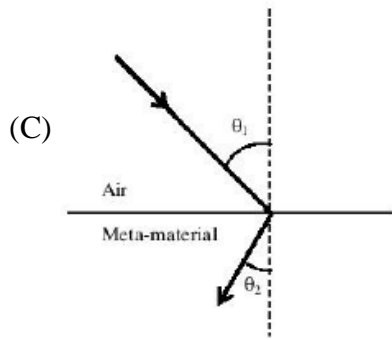

14. Choose the correct statement.

(A) The speed of light in the meta-material is $v = c|n|$

(B) The speed of light in the meta-material is $v = \frac{c}{|n|}$

(C) The speed of light in the meta-material is $v = c$.

(D) The wavelength of the light in the meta-material (λ_m) is given by $\lambda_m = \lambda_{air}|n|$, where λ_{air} is wavelength of the light in air.

SECTION III

This section contains **6 multiple choice questions**. Each question has four choices (A), (R), (C) and (D) out of which **ONE or MORE are correct**.

15. In the given circuit, the AC source has $\omega = 100 \text{ rad/s}$. Considering the inductor and capacitor to be ideal, the correct choice(s) is (are)

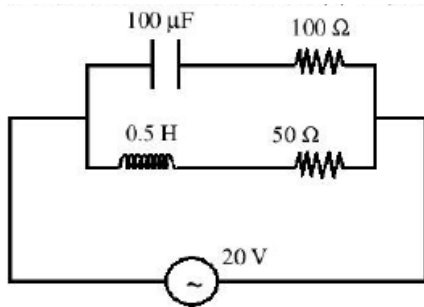

- (A) The current through the circuit, I is 0.3 A .
- (B) The current through the circuit, I is $0.3\sqrt{2} \text{ A}$.
- (C) The voltage across 100Ω resistor = $10\sqrt{2} \text{ V}$.
- (D) The voltage across 50Ω resistor = 10 V .
16. Six point charges are kept at the vertices of a regular hexagon of side L and centre O , as shown in the figure. Given that $K = \frac{1}{4\pi\epsilon_0} \frac{q}{L^2}$, which of the following statement(s) is (are) correct?

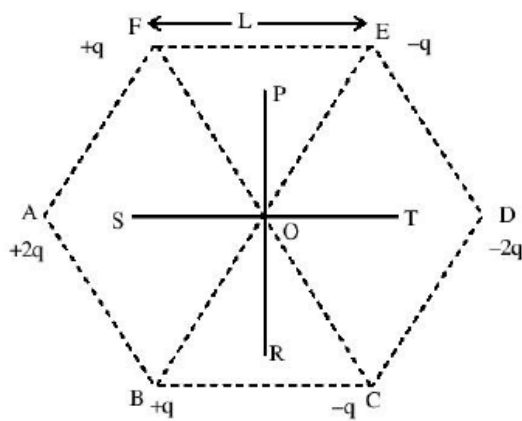

- (A) The electric field at O is $6K$ along OD .
- (B) The potential at O is zero.
- (C) The potential at all points on the line PR is same.
- (D) The potential at all points on the line ST is same.

17. Two spherical planets P and Q have the same uniform density ρ , masses M_p and M_Q and surface areas A and $4A$ respectively. A spherical planet R also has uniform density ρ and its mass is $(M_p + M_Q)$. The escape velocities from the planets P, Q and R are V_p, V_Q and V_R , respectively. Then

- (A) $V_Q > V_R > V_P$
- (B) $V_R > V_Q > V_P$
- (C) $V_R/V_P = 3$
- (D) $V_P/V_Q = \frac{1}{2}$

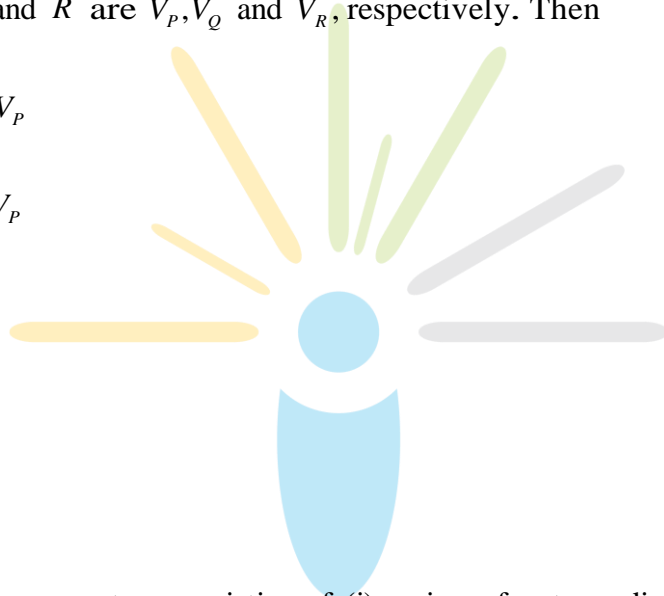

18. The figure shows a system consisting of (i) a ring of outer radius $3R$ rolling clockwise without slipping on a horizontal surface with angular speed ω and (ii) an inner disc of radius $2R$ rotating anti-clockwise with angular speed $\omega/2$. The ring and disc are separated by frictionless ball bearings. The point P on the inner disc is at a distance R from the origin, where OP makes an angle of 30° with the horizontal. Then with respect to the horizontal surface,

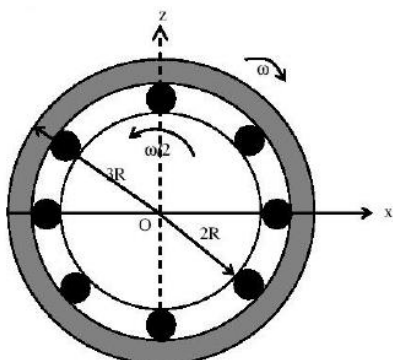

- (A) the point O has linear velocity $3R\omega\hat{i}$
- (B) the point P has linear velocity $\frac{11}{4}R\omega\hat{i} + \frac{\sqrt{3}}{4}R\omega\hat{k}$
- (C) the point P has linear velocity $\frac{13}{4}R\omega\hat{i} - \frac{\sqrt{3}}{4}R\omega\hat{k}$
- (D) the point P has linear velocity $\left(3 - \frac{\sqrt{3}}{4}\right)R\omega\hat{i} + \frac{1}{4}R\omega\hat{k}$
19. Two solid cylinders P and Q of same mass and same radius start rolling down a fixed inclined plane from the same height at the same time. Cylinder P has most of its mass concentrated near its surface, while Q has most of its mass concentrated near the axis. Which statement(s) is(are) correct?
- (A) Both cylinders P and Q reach the ground at the same time.
- (B) Cylinder P has larger linear acceleration than cylinder Q .
- (C) Both cylinders reach the ground with same translational kinetic energy.
- (D) Cylinder Q reaches the ground with larger angular speed.
20. A current carrying infinitely long wire is kept along the diameter of a circular wire loop, without touching it, the correct statement(s) is(are)
- (A) The emf induced in the loop is zero if the current is constant.
- (B) The emf induced in the loop is finite if the current is constant.
- (C) The emf induced in the loop is zero if the current decreases at a steady rate.
- (D) The emf induced in the loop is infinite if the current decreases at a steady rate.